



# **SPARX 10**

## Operating Instructions

Version 1.8  
Software >= 1.23

Contains also French warnings!  
Comprend les avertissements en langue français

## Content

English

<b>1. Dimensions &amp; product overview</b>	<b>.05</b>
<b>2. Introduction</b>	<b>.06</b>
2.1 Safety instruction	06
2.2 Unpacking	06
<b>3. Installation</b>	<b>.06</b>
3.1 Connection to Mains	06
3.2 Rigging the fixture	07
3.3 DMX wiring	08
3.4 Installing a plug on the power cord	08
3.5 Relaying power to other fixtures	08
<b>4. Control panel</b>	<b>.09</b>
4.1 Menu navigation	10
4.2 FACTORY DEFAULTS	12
4.3 USER DEFAULTS	12
4.4 DMX ADDRESS	12
4.5 PERSONALITY	12
4.6 STANDALONE mode	13
4.7 INFO	14
<b>5. DMX protocol</b>	<b>.15</b>
5.1 Color mixing	31
5.2 Control channel	31
5.3 User notes	31
<b>6. Service</b>	<b>.33</b>
6.1 Service menu	33
6.2 Cleaning the fixture	34
6.3 Software update	34
6.4 Verifying electronic devices	34
<b>7. Specifications</b>	<b>.35</b>
<b>8. Declaration of conformity</b>	<b>.36</b>

## 1. Dimensions & product overview



## 2. Introduction

### 2.1 Safety instruction



WARNING: This device is for professional use only! Protection rating IP 20 - only indoor use



WARNING: LED Radiation - do not look into the beam at a distance of less than 5 meters (197 inches) from the front surface of the product. Do not view the light output with optical instruments or any device that may concentrate the beam. LED class 3 according to EN 62471.



WARNING: JB-Lighting Lichtenlagentechnik GmbH does not authorize or warrant its products for use in life support systems. Life support systems are equipment intended to support or sustain life, and whose failure to perform, when properly used in accordance with instructions provided, can be reasonably expected to result in personal injury or death.

This product conforms to the European Community Directives:

- Low voltage directive 2014/35/EU
- Electromagnetic compatibility 2014/30/EU



ATTENTION: Cet appareil ne convient que pour un usage professionnel! Degré de protection: IP 20



ATTENTION: Rayonnement LED - Ne pas regarder le faisceau à moins de 5m ou à l'aide d'un instrument à optiques. LED classe 3 selon la norme DIN EN 62471



ATTENTION: JB-Lighting Lichtenlagentechnik GmbH n'autorise pas l'utilisation de leurs appareils dans des systèmes ou dispositifs permettant le maintien en vie. Sont considérés systèmes ou dispositifs de maintien en vie tous systèmes qui ont pour but de maintenir la vie ou de la stabilisée et qu'un défaut ou défaillance éventuelle de celui-ci ne blesse ou entraîne la mort d'autrui.

Le produit décrit dans ce manuel est conforme aux directives Européennes suivantes:

- Directive appliquée à la Basse Tension 2014/35/EU
- Directive CEM 2014/30/EU

### 2.2 Unpacking

This package contains the Sparx10, two omega brackets with 1/4 turn fasteners, this manual (one per shipment) as well as a power cable with PowerCon connector (no cable in US model). Open the top of the box and remove the inlay. Remove the unit from the box. For any damage occurring during transport, report to the transport company immediately.

## 3. Installation

### 3.1 Connection to Mains



WARNING: To ensure proper installation of the plug consult a qualified technician!

ATTENTION: Installation de la connexion au réseau doit être effectuée par un professionnel!

# SPARX 10

The Sparx10 is supplied with a power cable with a Neutrik PowerCon connector. Install a 3-prong grounding type plug that fits your supply. US model comes without power cable and connectors. Required cable type see 4.5. Connected load: voltage 100-240 V, frequency 50 - 60 Hz

## Connection EU-model:

Color	Function	Symbol
brown	Live	„L“
blue	Neutral	„N“
green/yellow	Ground	

## Connection non EU-model:

The Sparx10 may only be connected to mains supply systems according to this drawing:

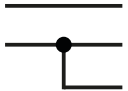
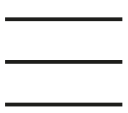
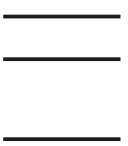
	mains		Sparx10
2 conductor 1 phase	L N		L N PE
3 conductor 1 phase	L N L		L PE N
4 conductor 3 phase	L <sub>1</sub> L <sub>2</sub> L <sub>3</sub> N		L N PE



WARNING: only can be used in Canadian mains supply system with 2 conductor, 1 phase with max. 120V!

ATTENTION: Le A8 peut être utilisé au Canada avec 2 conducteurs, 1 phase et une tension maximal de 120V!

## 3.2 Rigging the fixture



WARNING: Keep fixtures at least 1,0 meter away from inflammable articles! Always use a safety cable attached to the base!

ATTENTION: Respecter une distance minimale de 1,0 m entre le projecteur est d'éventuelles objets inflammables! Sécuriser toujours le Sparx10 avec une élingue de sécurité appropriée!

The Sparx10 can either be placed on the floor or hang on a trussing system in any position. When placing the unit on the floor make sure that it stands on rigid ground, because the air inlets in the base must not be covered with anything! To mount the unit on a trussing system use two of the original JB-Lighting omega brackets with Camloc-connectors. The Camlocs must snap in to be locked properly. Always attach a safety cable to secure the unit.

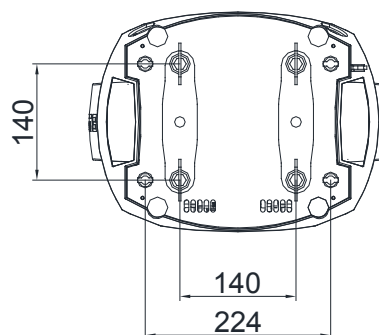

### 3.3 DMX wiring

Use a shielded twisted-pair cable with two pairs to connect the serial link. Connect all pins if you want to upgrade the software in cross-load. If a microphone cable (or any other cable with only one pair) is used the software can not be updated via DMX line because pin 4 and 5 are not connected.

Pin assignment:

- Pin 1 = shield
- Pin 2 = data -
- Pin 3 = data +
- Pin 4 = data out -
- Pin 5 = data out +

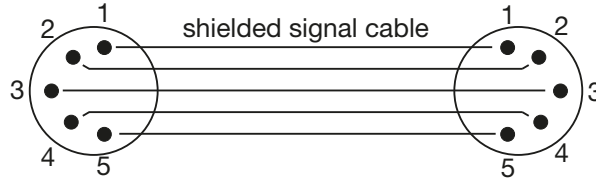

The Sparx10 has 3pin and 5pin XLR connectors for DMX-in and DMX-out. Do not connect more than one data input and one data output on a fixture.

Connect the DMX-out of the control desk to the first Sparx10 in line. (lighting control desk DMX-Out -> Sparx10 DMX-in). Connect the second Sparx10 to the first in line, and so on (Sparx10 no. 2 DMX-In -> Sparx10 no. 1 DMX-Out). All 3-pin and 5-pin connectors are wired parallel. Do not use this fixture as a DMX splitter! The DMX-Out of the last unit in line is not occupied unless problems occur. Then use a termination plug with the last Sparx10 in line. (XLR-connector with a 120 Ohm resistor soldered between pin 2 and pin 3). Problems might occur when the line is overloaded, e.g.

### 3.4 Installing a plug on the power cord

Install a plug like described in chapter 3.1.

Connected load: Voltage 100-240 Volts, frequency 50 - 60 Hz, power max. 600 VA. Connect the fixture to a proper installed grounded system only. If any doubts on the electrical installations occur, consult a qualified electrician. In case of damages occurring due to a not proper installed electrical system, warranty claims will be invalidated. Don't use fixtures when top cover is not fixed properly. Contact with electronic parts can result in risk for life. (Electrical shock 100-240 V)

Connect fixture only after assuring that the electrical installation fits your demands. If any doubts occur consult a qualified technician!



**WARNING:** Sparx10 might light up immediately if standalone mode is active or DMX signal is connected!

**ATTENTION:** Le projecteur Sparx10 peut s'illuminer directement, lorsque le mode standalone est activé ou si un signal DMX est programmé!

### 3.5 Relaying power to other fixtures



**WARNING:** To ensure proper installation of the plug consult a qualified technician!

**ATTENTION:** Installation de la connexion au réseau doit être effectuée par un professionnel!

Power can be relayed to another device via the grey PowerCon throughput socket that accepts a grey PowerCon NAC3FCB cable connector. Note that blue input and grey throughput connectors have different design: one type cannot be connected to the other.

The value of Sparx10 in chain depends on the local power network. Never use more than five in one line. Power throughput cable must be rated 20A min., have three conductors 1,5mm<sup>2</sup> min. conductor size and a outer cable diameter of 5-15mm. Use only original PowerCon plug from Neutrik. See installation manual from manufacturer ([www.neutrik.com](http://www.neutrik.com)).

Color	Function	Symbol
brown	Live	„L“
blue	Neutral	„N“
green/yellow	Ground	

## 4. Control panel

The Sparx10 is equipped with a backlit graphic display, which can be rotated through 180 deg. if the unit is installed upside down.

### Rotating the display



Use the centred button to change the orientation of the display. To adjust the personal setting of the Sparx10 use keys located on the control panel. Functions see menu on the following page. The Sparx10 can be addressed in the main menu. For addressing in a case, the reset can be aborted by pressing the right base button during powering the fixture. The main menu also informs about the DMX-mode. If wireless DMX is used, the field intensity from the sender will be displayed. Press „ENTER“ to enter a menu, select a function or apply a selection. Press keys „DOWN“ and „UP“ to scroll within a menu or set values. To escape a function press key „ESC“. A few functions can be entered or recalled by means of a combination of two keys. For example FINE ADJUST at menu SERVICE and MODIFY, RUN and REMOTE at menu STANDALONE. To enter these functions press „ENTER“, keep it down and press „ESC“ in addition. To leave the menu press „ESC“ hold it down and press „Enter“, MODIFY and FINE ADJUST you can leave only by pressing „ESC“.

The main menu can be locked to avoid an accidental change of the configuration. To lock press „ENTER“ and keep it down and press „ESC“ in addition. To unlock press „ESC“ (keep it down) and press „ENTER“ in addition.

### Special functions are assigned to the display lighting:

The display is not illuminated during reset. Slow flashing of the display illumination means no DMX signal is connected. Fast flashing of the display illumination showing „JB-Lighting“ means a failure was reported and stored in the ERROR LIST (To clear - see menu navigation on next page). Fast flashing of the display illumination showing an error message means an current failure is reported, e. g. \*PAN TIMEOUT - please contact your dealer or our service department. If the Sparx10 receives a DMX-signal the display illumination dims out after 30 seconds in order not to irritated during standard operation.

### 4.1 Menu navigation

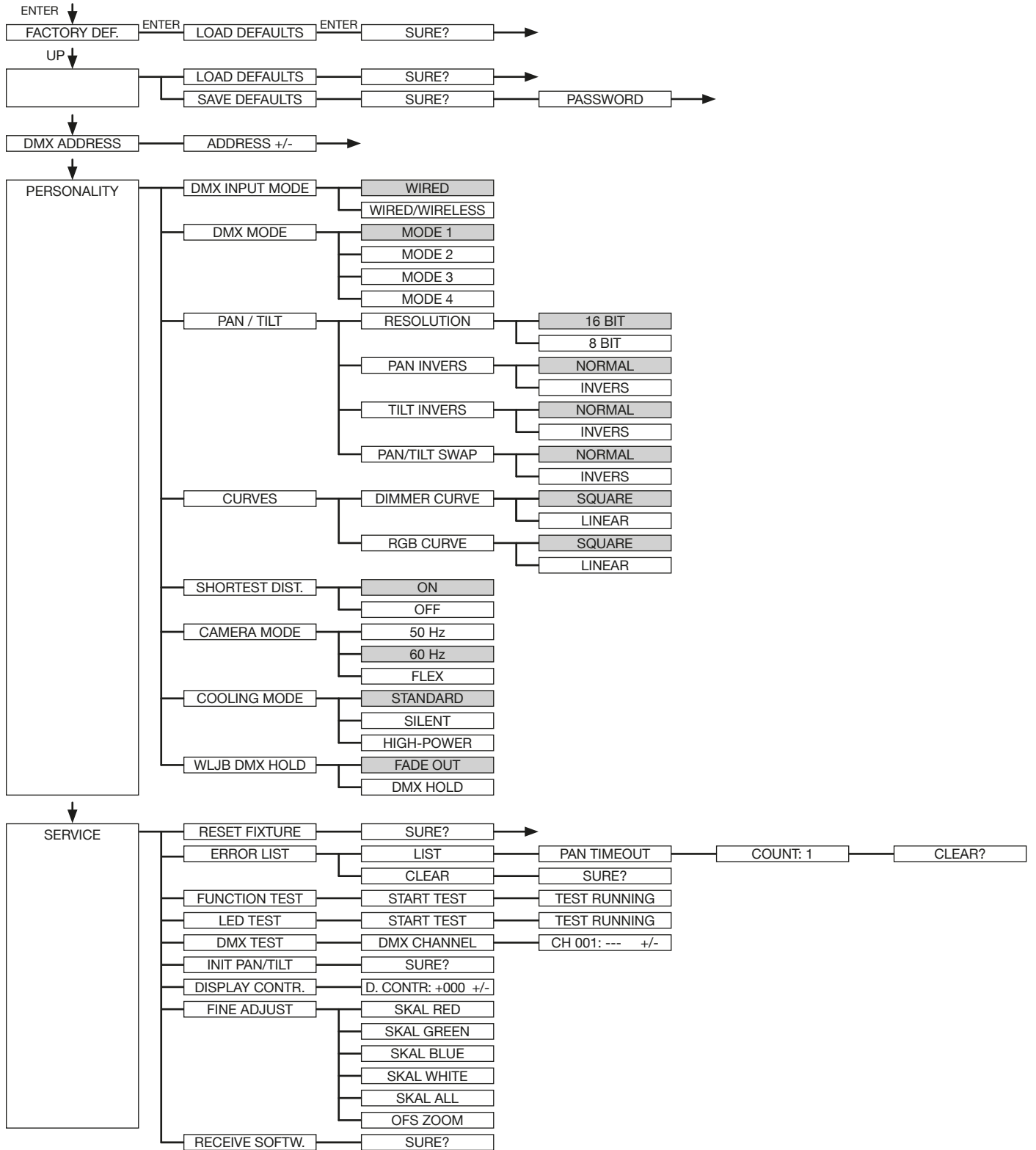

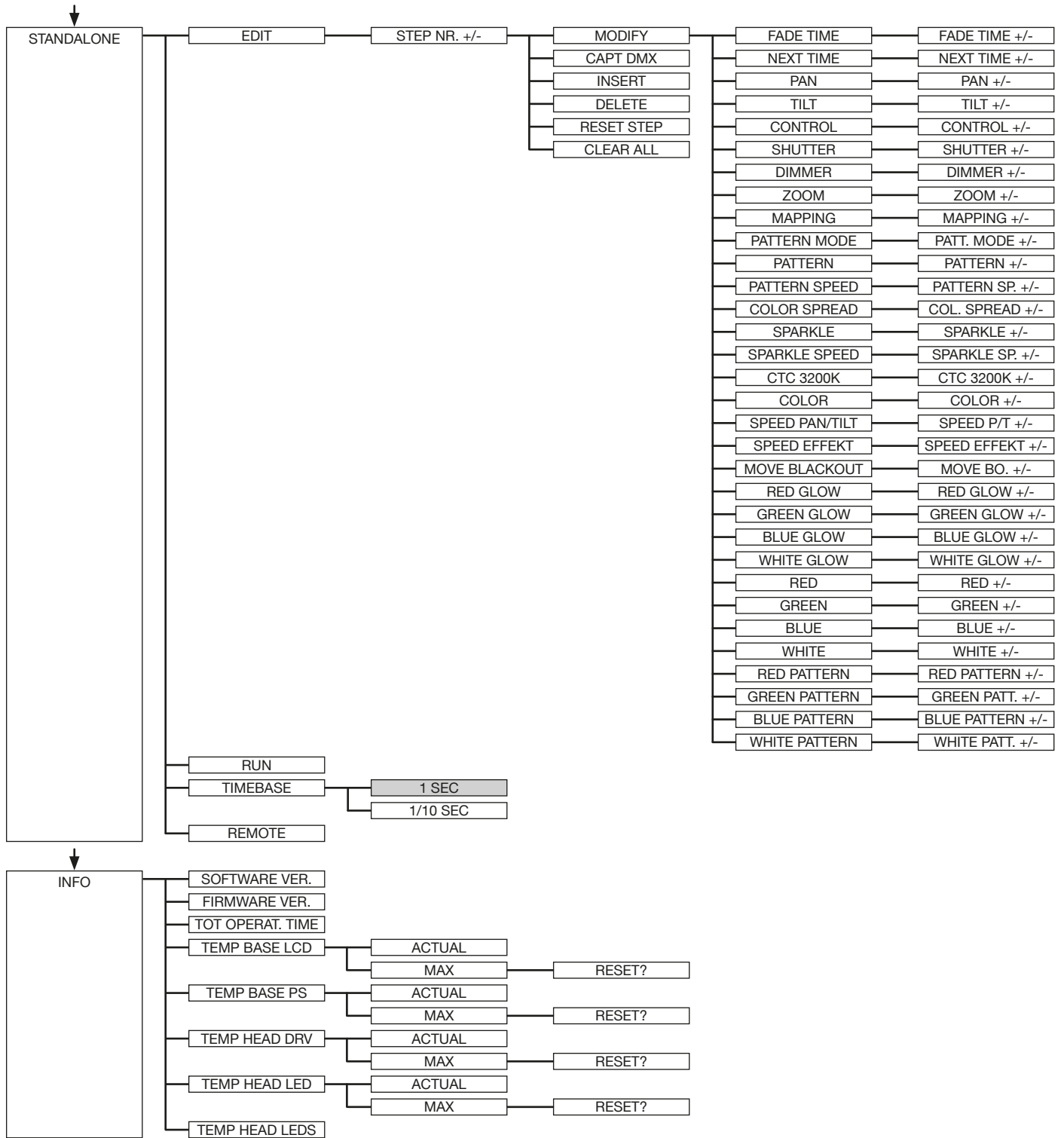

## **4.2 FACTORY DEFAULTS**

To set back the Sparx10 to factory defaults choose in the menu FACTORY DEFAULT -> LOAD DEFAULTS. After confirming SURE? with ENTER, the personal settings of the Sparx10 will be set back to factory defaults.

If the white balance was adjusted before, it will be not affected by the set back to factory defaults.

## **4.3 USER DEFAULTS**

If personal settings are done in the PERSONALITY menu, the user can save and reload it in the USER DEFAULTS menu. To make sure that the personal settings are not changed quickly on a stage, the save progress is locked with the password „JB-LIGHTING“.

## **4.4 DMX ADDRESS**

Change the DMX address directly by pressing the keys „UP“ and „DOWN“. Confirm and store it by pressing key „ENTER“. The DMX address can also be changed in the menu DMX ADDRESS.

## **4.5 PERSONALITY**

### **DMX INPUT MODE**

The Sparx10 provides an embedded radio-DMX receiver. The receiver works with the JB-Lighting Wireless TRX transmitter. To enable the Sparx10 to receive radio-DMX change the menu from WIRED (factory default) to WIRED/WIRELESS. The fixture needs to be logged in to the Wireless TRX transmitter. To log-in press the „Start“ button (see also manual Wireless TRX). The radio channel is displayed when the Sparx10 is logged. The main display will show the intensity of the incoming signal. If the Sparx10 is connected either via DMX cable and radio-DMX, the cable signal has priority.

### **DMX MODE**

The Sparx10 offers 3 different operating modes (see DMX protocol page 40). Mode 1 is an 8 bit mode with which you can control all features of your Sparx10. For using the full range of DMX channels use the mode 2 - 16 BIT. Use this mode for smoother operation with the RGBW channels. In order to operate the Sparx10 with less DMX channels the DMX mode can be set to mode 3. In this mode there are all channels in 8 bit mode without Pan/Tilt.

### **PAN / TILT**

RESOLUTION sets pan and tilt to 8 bit or 16 bit control resolution. The default setting is 16 bit. If this fine resolution is not required, you can set to 8 bit for quicker operation of pan/tilt values. The PAN INVERS and TILT INVERS commands invert the direction of pan and tilt. The PAN/TILT SWAP command sets pan commands to tilt and vice versa.

### **CURVES**

Dimming curves can be adjusted for the dimmer channel and the RGBW channels. There is a square-law curve for finer control at low intensity and coarser control at high intensity and a linear-law curve available.

### **SHORTEST DISTANCE**

This setting is only for the color wheel channel. Switched to ON (default) it always take the shortest route from one colour to another in order to simulate a physical color wheel. Switched to OFF it routes only from white to turquoise and backwards.

### **CAMERA MODE**

For flicker free recording in TV-studios the Sparx10 offers three different modes from 50 Hertz (PAL, Secam) to 60 Hertz (NTSC). Flex mode is designed, if cameras have a refresh frequency that makes the 50 or 60Hz settings ineffective. Factory default is 60Hz. Access the menu PERSONALITY -> CAMERA MODE and choose the required frequency. To confirm press „ENTER“. This can be also controlled with the control channel (channel 5) via lighting desk.

## **COOLING MODE**

The Sparx10 offers three different modes for fan operation. The default setting STANDARD will suit most applications. Switch to SILENT to reduce the speed of the fans to a minimum. This mode is to be used only in well ventilated rooms with low ambient temperature, with reduced light output or if the fixture is only required occasionally. The HI POWER mode is designed to be used in areas with higher air temperature or for fixed installations. The fans start to run faster with more airflow which produces more noise.

There is no mode danger for the lifetime of the Sparx10. If the temperature rises too much the fixture switches off automatically.

## **WLJB DMX HOLD**

The behaviour of the Sparx10 in case the wireless DMX connection is interrupted can be set to:

1. DMX Hold - Sparx10 freezes on the last received DMX value.
2. Fade out - Sparx10 fades out after 5 seconds.

When DMX signal is back the Sparx10 first turns to its new position and fades in.

## **4.6 STANDALONE mode**

A sequence, up to 20 steps, consisting of preprogrammed cues can be recalled by means of the STANDALONE MODE. The sequence will run as a loop. Cues can be entered in two different ways. The first way is to program every feature by means of the keys of the units on-board control panel. The second way is to program the cues by means of a connected DMX control console and to store them in the fixture.

**IMPORTANT!** The functions MODIFY, RUN and REMOTE can be accessed only by pressing a combination of keys and not just by pressing „ENTER“. Before activating the functions make sure that there is just one DMX-transmitter in the DMX-line (e.g. one control console or one master fixture). A number of DMX-transmitters can damage the DMX driver of the fixtures. To enter the functions press “ENTER” (keep it down) and press „ESC“ in addition.

### **Programming the stand alone sequence:**

Enter the menu STANDALONE -> EDIT. STEP NR 01/01 will be displayed. Enter the MODIFY menu to get access to the fixtures functions. Recall the functions and enter DMX values. Enter FADE TIME (during which the effects will move to the programmed position) Enter NEXT TIME which will be the duration of the step. Add a new step with INSERT. The DMX values of the last step will be automatically copied to the new step. With DELETE one step of the sequence can be deleted. Choose the step and confirm the function with ENTER. To reset the DMX values of a step use RESET STEP. Select the step and confirm with “ENTER”. All DMX values of the step will be set to zero. With CLEAR ALL the complete sequence will be deleted and the display will show STEP 01/01

### **Store cues from a DMX controller:**

The DMX values can also be programmed by means of a DMX console. Enter the STANDALONE menu and navigate to CAPT DMX. Program the DMX values with an external DMX console. To capture the data press „ENTER“. The fixtures display will show START CAPTURE. To insert, delete or reset use the keys of the control panel of the fixture.

### **Activate the standalone mode:**

The standalone mode is activated in the menu STANDALONE -> RUN. To enter the functions press “ENTER” (keep it down) and press “ESC” in addition. Sparx10 will execute sequence in a repeating loop. To leave press “ESC” and hold it down and press “ENTER” in addition.

**Operation in Master-Slave mode:**

To set a fixture to slave-mode navigate to REMOTE. To activate the slave function press “ENTER” (keep it down) and press “ESC” in addition. The display will show either REMOTE INACTIVE if no DMX-signal is being received or REMOTE ACTIVE if a DMX-signal is being received. To leave this function press “ESC” (keep it down) and press “ENTER” in addition. Connect the Sparx10 with DMX cables. Select STANDALONE -> RUN with the master fixture. Start function by pressing “ENTER” (keep it down) and pressing “ESC” in addition. All connected fixtures will repeat the steps synchronized to the master fixture. To leave the menu press “ESC” (keep it down) and press “ENTER” in addition. If you realize that a fixture reacts inaccurate check if the display shows REMOTE ACTIVE.

**Pre-load Demo:**

The Sparx10 provides 20 pre-programmed Effects in the Pre-load demo menu. The user can load it and change the values with MODIFY. A quick introducing in the effects of Sparx10 can be done.

**4.7 INFO**

The menu informs about the current software/firmware version. The non-resettable TOT OPERATE TIME counter displays total hours of use since the Sparx10 was manufactured.

Temperature readouts from the display panel (TEMP BASE LCD) and power supply unit (TEMP BASE PS) in the base as well as the driver (TEMP HEAD DRV) and LED PCB (TEMP HEAD LED) in the head are available. In each case, you can view the current temperature and the maximum temperature reached since the readout was last reset individually. The TEMP HEAD LEDs views the actual temperature of the single LEDs.

## 5. DMX protocol

The Sparx10 offers 4 different channel modes. The mode can be set in menu item PERSONALITY -> DMX MODE. The used mode will be displayed in the main menu.

	Mode 1 (M1)	Mode 2 (M2)	Mode 3 (M3)	Mode 4 (M4)
Channel 1	Pan	Pan	Pan	Pan
Channel 2	Pan fine	Pan fine	Pan fine	Pan fine
Channel 3	Tilt	Tilt	Tilt	Tilt
Channel 4	Tilt fine	Tilt fine	Tilt fine	Tilt fine
Channel 5	Control	Control	Control	Control
Channel 6	Shutter	Shutter	Shutter	Shutter
Channel 7	Dimmer	Dimmer	Dimmer	Dimmer
Channel 8	Zoom	Zoom	Zoom	Zoom
Channel 9	Mapping	Mapping	Mapping	Mapping
Channel 10	Pattern mode	Pattern mode	Pattern mode	Pattern mode
Channel 11	Pattern	Pattern	Pattern	Pattern
Channel 12	Pattern speed	Pattern speed	Pattern speed	Pattern speed
Channel 13	Color spread	Color spread	Color spread	Color spread
Channel 14	Sparkle	Sparkle	Sparkle	Sparkle
Channel 15	Sparkle speed	Sparkle speed	Sparkle speed	Sparkle speed
Channel 16	CTC 3200K	CTC 3200K	CTC 3200K	CTC 3200K
Channel 17	Fixed colors	Fixed colors	Fixed colors	Fixed colors
Channel 18	Pan/Tilt speed	Pan/Tilt speed	Pan/Tilt speed	Pan/Tilt speed
Channel 19	Effect speed	Effect speed	Effect speed	Effect speed
Channel 20	Blackout move	Blackout move	Blackout move	Blackout move
Channel 21	Red	Red	Red	Red
Channel 22	Green	Red fine	Green	Green
Channel 23	Blue	Green	Blue	Blue
Channel 24	White	Green fine	White	White
Channel 25	Red	Blue		Red
Channel 26	Green	Blue fine		Green
Channel 27	Blue	White		Blue
Channel 28	White	White fine		White
Channel 29	Red	Red		Red
Channel 30	Green	Red fine		Green
Channel 31	Blue	Green		Blue
Channel 32	White	Green fine		White
Channel 33		Blue		Transition / crossfade
Channel 34		Blue fine		Red (LED group 1)
Channel 35		White		Green (LED group 1)
Channel 36		White fine		Blue (LED group 1)
Channel 37		Red		White (LED group 1)
Channel 38		Red fine		Red (LED group 2)
Channel 39		Green		Green (LED group 2)
Channel 40		Green fine		Blue (LED group 2)
Channel 41		Blue		White (LED group 2)
Channel 42		Blue fine		Red (LED group 3)
Channel 43		White		Green (LED group 3)
Channel 44		White fine		Blue (LED group 3)
Channel 45				White (LED group 3)





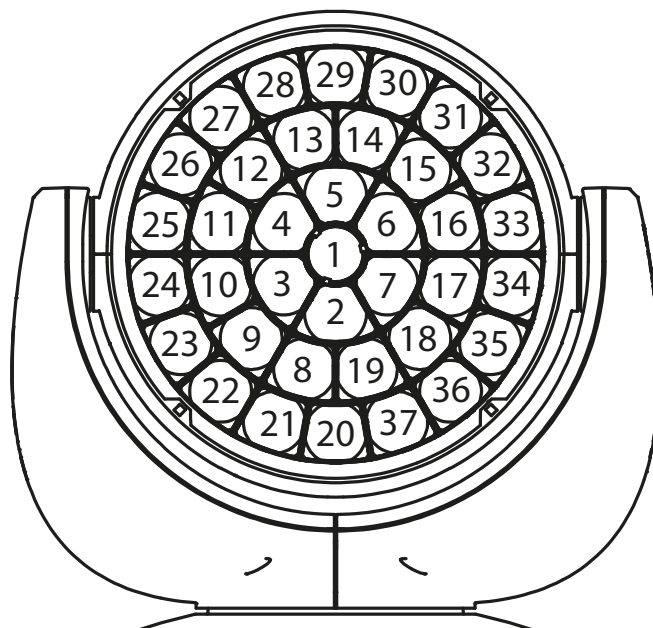

Mode 1 (M1)	Mode 2 (M2)	Mode 3 (M3)	Mode 4 (M4)
Channel 46			Red (LED group 4)
Channel 47			Green (LED group 4)
Channel 48			Blue (LED group 4)
Channel 49			White (LED group 4)
Channel 50			Red (LED group 5)
Channel 51			Green (LED group 5)
Channel 52			Blue (LED group 5)
Channel 53			White (LED group 5)
Channel 54			Red (LED group 6)
Channel 55			Green (LED group 6)
Channel 56			Blue (LED group 6)
Channel 57			White (LED group 6)
Channel 58			Red (LED group 7)
Channel 59			Green (LED group 7)
Channel 60			Blue (LED group 7)
Channel 61			White (LED group 7)
Channel 62			Red (LED group 8)
Channel 63			Green (LED group 8)
Channel 64			Blue (LED group 8)
Channel 65			White (LED group 8)
Channel 134			Red (LED group 26)
Channel 135			Green (LED group 26)
Channel 136			Blue (LED group 26)
Channel 137			White (LED group 26)
Channel 138			Red (LED group 27)
Channel 139			Green (LED group 27)
Channel 140			Blue (LED group 27)
Channel 141			White (LED group 27)
Channel 142			Red (LED group 28)
Channel 143			Green (LED group 28)
Channel 144			Blue (LED group 28)
Channel 145			White (LED group 28)
Channel 146			Red (LED group 29)
Channel 147			Green (LED group 29)
Channel 148			Blue (LED group 29)
Channel 149			White (LED group 29)
Channel 150			Red (LED group 30)
Channel 151			Green (LED group 30)
Channel 152			Blue (LED group 30)
Channel 153			White (LED group 30)



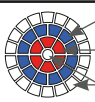



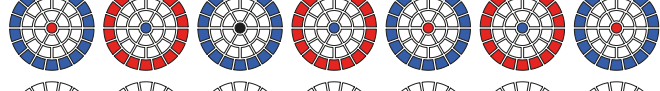









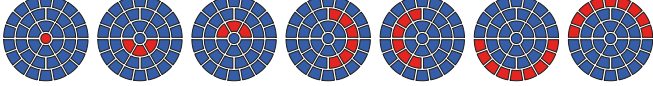

Mode 1 (M1)	Mode 2 (M2)	Mode 3 (M3)	Mode 4 (M4)
Channel 154			Red (LED group 31)
Channel 155			Green (LED group 31)
Channel 156			Blue (LED group 31)
Channel 157			White (LED group 31)
Channel 158			Red (LED group 32)
Channel 159			Green (LED group 32)
Channel 160			Blue (LED group 32)
Channel 161			White (LED group 32)
Channel 162			Red (LED group 33)
Channel 163			Green (LED group 33)
Channel 164			Blue (LED group 33)
Channel 165			White (LED group 33)
Channel 166			Red (LED group 34)
Channel 167			Green (LED group 34)
Channel 168			Blue (LED group 34)
Channel 169			White (LED group 34)
Channel 170			Red (LED group 35)
Channel 171			Green (LED group 35)
Channel 172			Blue (LED group 35)
Channel 173			White (LED group 35)
Channel 174			Red (LED group 36)
Channel 175			Green (LED group 36)
Channel 176			Blue (LED group 36)
Channel 177			White (LED group 36)
Channel 178			Red (LED group 37)
Channel 179			Green (LED group 37)
Channel 180			Blue (LED group 37)
Channel 181			White (LED group 37)











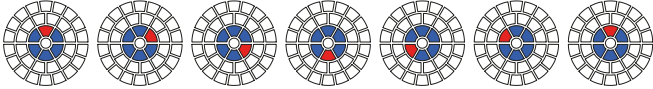
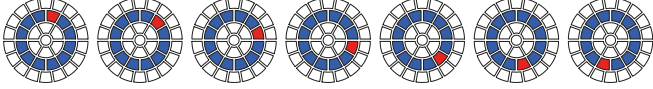
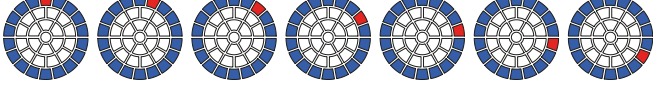

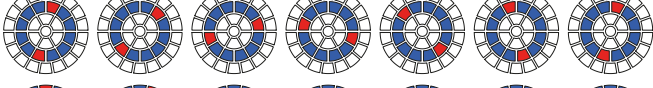
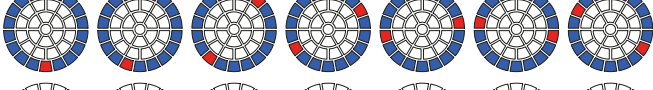
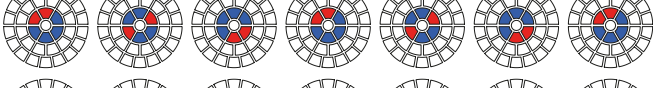
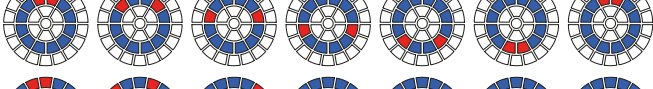
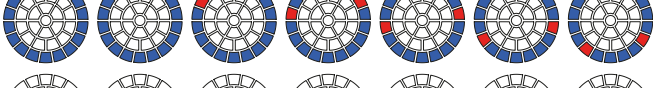
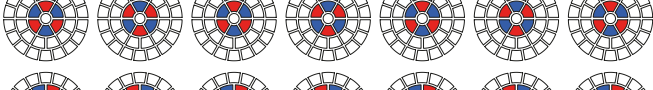
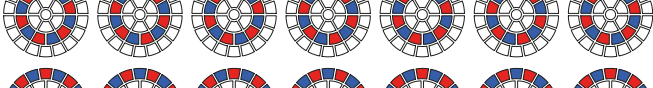
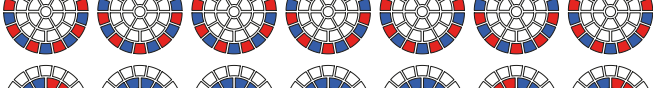
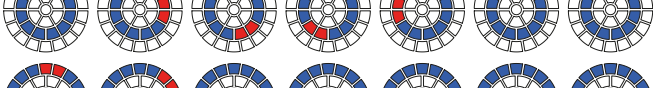
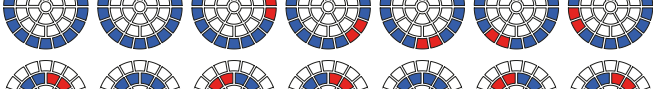
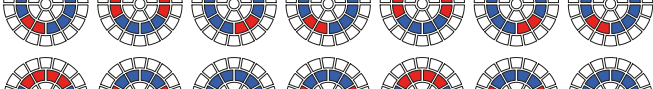
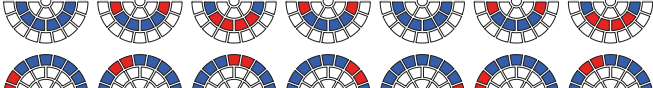
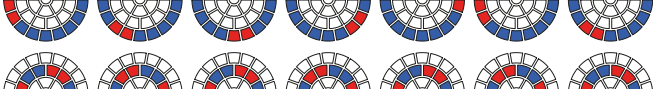
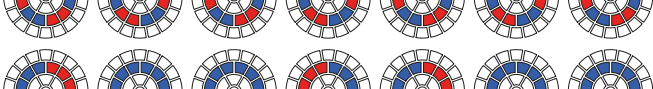
The Pan/Tilt values are at 127/60. The display of the fixture is looking in the same direction like the LED's



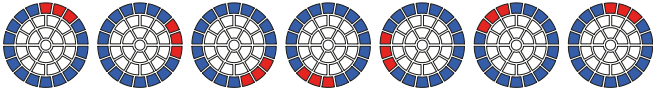
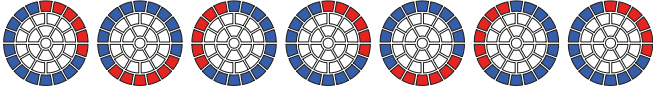

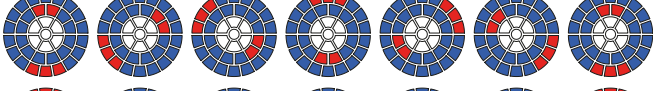
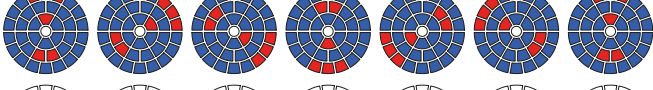
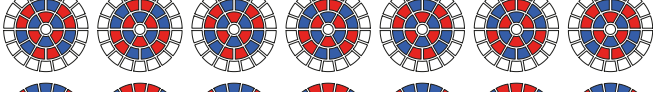
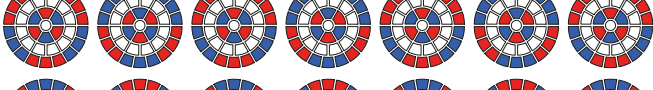
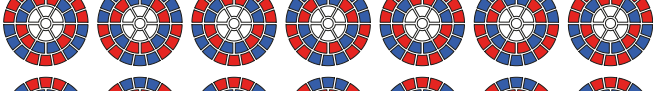
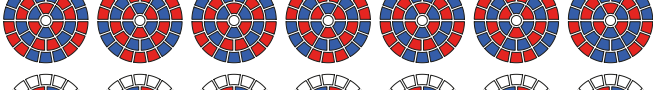
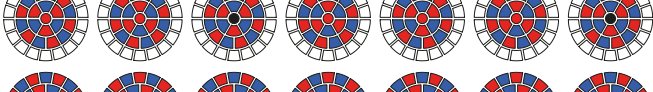
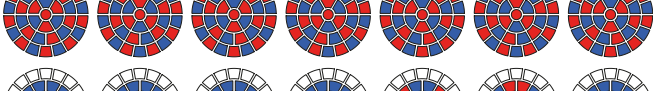
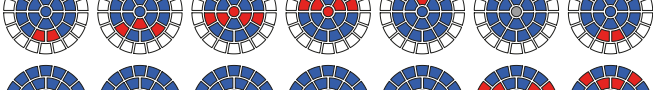
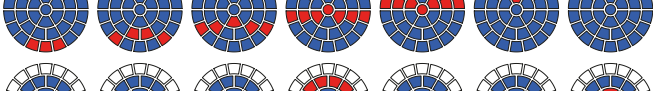
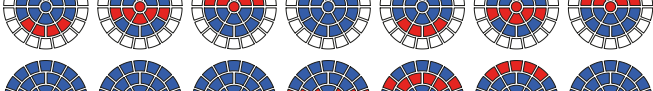

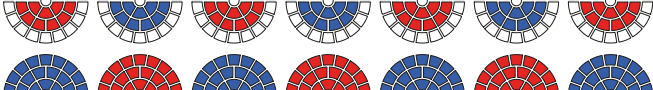
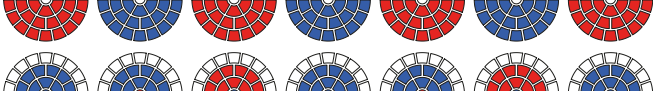
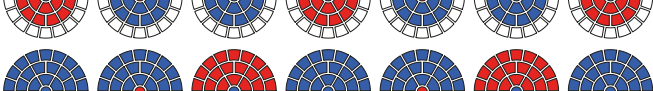









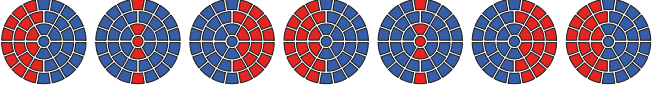

M1	M2	M3	M4	Function	DMX	
1	1	1	1	<b>Pan (X)</b> movement 433,6°	000-255	
2	2	2	2	<b>Pan (X)</b> fine	000-255	
3	3	3	3	<b>Tilt (Y)</b> movement 333,3°	000-255	
4	4	4	4	<b>Tilt (Y)</b> fine	000-255	
5	5	5	5	<b>Control</b> Full output power on LEDs Fade out with fader (slow - fast) Basic adjustment RGB Fade out with fader (slow - fast) White balance RGB (same white as fixed colors color 0) Fade out with fader (slow - fast) Color balance for color picker function Fade out with fader (slow - fast)  Full output power on LEDs Fade out with fader (slow - fast) Basic adjustment RGB Fade out with fader (slow - fast) White balance RGB (same white as fixed colors color 0) Fade out with fader (slow - fast) Color balance for color picker function Fade out with fader (slow - fast)  Full output power on LEDs Fade out with fader (slow - fast) Basic adjustment RGB Fade out with fader (slow - fast) White balance RGB (same white as fixed colors color 0) Fade out with fader (slow - fast) Color balance for color picker function Fade out with fader (slow - fast)  Full output power on LEDs Fade out with fader (slow - fast) Basic adjustment RGB Fade out with fader (slow - fast) White balance RGB (same white as fixed colors color 0) Fade out with fader (slow - fast) Color balance for color picker function Fade out with fader (slow - fast)  Full output power on LEDs Fade out with fader (slow - fast) Basic adjustment RGB Fade out with fader (slow - fast) White balance RGB (same white as fixed colors color 0) Fade out with fader (slow - fast) Color balance for color picker function Fade out with fader (slow - fast)	 Lighting desk mode 1 (reaction time fast)  Lighting desk mode 2  Lighting desk mode 3  Lighting desk mode 4  Lighting desk mode 5 (reaction time slow)	000-007 008-015 016-023 024-031  032-039 040-047 048-055 056-063  064-071 072-079 080-087 088-095  096-103 104-111 112-119 120-127  128-135 136-143 144-151 152-159



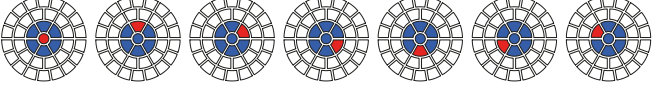



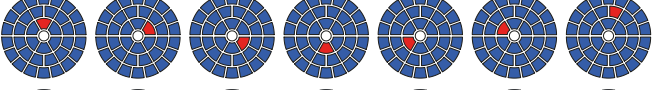







				Safe Camera mode, 50Hz (after 2 seconds) Camera mode, 60Hz (after 2 seconds) Camera mode, FLEX (after 2 seconds) Safe Reset (after 2 seconds) Safe	160-207 208-215 216-223 224-231 232-239 240-247 248-255
6	6	6	6	<b>Shutter</b> Shutter closed Shutter open Shutter pulse opening >10Hz (0,6 sec - 4,8 sec) Shutter open Fade effect with dimmer (slow - fast) Shutter open Shutter closed Shutter pulse opening <10Hz (0,6 sec - 4,8 sec) Shutter open Shutter pulse closing (0,6 sec - 4,8 sec) Shutter closed Shutter fade, 0% (0,6 sec - 4,8 sec) Shutter open Shutter fade, 100% (0,6 sec - 4,8 sec) Shutter closed Shutter random 100% (0,6 sec - 4,8 sec) Shutter open Shutter random 0% (0,6 sec - 4,8 sec) Shutter closed Shutter random fade 0% (0,6 sec - 4,8 sec) Shutter open Shutter random fade 100% (0,6 sec - 4,8 sec) Shutter open	000-015 016-095 096-110 111-111 112-125 126-126 127-126 128-142 143-143 144-158 159-159 160-174 175-175 176-190 191-191 192-206 207-207 208-222 223-223 224-238 239-239 240-254 255-255
7	7	7	7	<b>Dimmer</b> 0 - 100%	000-255
8	8	8	8	<b>Zoom</b> 0-100% (narrow 4° - wide 40°)	000-255
9	9	9	9	<b>Mapping - segment selection</b>  Background color (blue) - RGBW Main Foreground color (red) - RGBW Pattern Not active (white) - resp. RGBW Glow  No mapping, pattern circular Segment 01  Segment 02  Segment 03  Segment 04  Segment 05  Segment 06 	000-000 001-001  002-002  003-003  004-004  005-005  006-006

			Segment 07		007-007
			Segment 08		008-008
			Segment 09		009-009
			Segment 10		010-010
			Segment 11		011-011
			Segment 12		012-012
			Segment 13		013-013
			Segment 14		014-014
			Segment 15		015-015
			Segment 16		016-016
			Segment 17		017-017
			Segment 18		018-018
			Segment 19		019-019
			Segment 20		020-020
			Segment 21		021-021
			Segment 22		022-022
			Segment 23		023-023
			Segment 24		024-024
			Segment 25		025-025
			Segment 26		026-026

			Segment 27		027-027
			Segment 28		028-028
			Segment 29		029-029
			Segment 30		030-030
			Segment 31		031-031
			Segment 32		032-032
			Segment 33		033-033
			Segment 34		034-034
			Segment 35		035-035
			Segment 36		036-036
			Segment 37		037-037
			Segment 38		038-038
			Segment 39		039-039
			Segment 40		040-040
			Segment 41		041-041
			Segment 42		042-042
			Segment 43		043-043
			Segment 44		044-044
			Segment 45		045-045
			Segment 46		046-046

			Segment 47		047-047
			Segment 48		048-048
			Segment 49		049-049
			Segment 50		050-050
			Segment 51		051-051
			Segment 52		052-052
			Segment 53		053-053
			Segment 54		054-054
			Segment 55		055-055
			Segment 56		056-056
			Segment 57		057-057
			Segment 58		058-058
			Segment 59		059-059
			Segment 60		060-060
			Segment 61		061-061
			Segment 62		062-062
			Segment 63		063-063
			Segment 64		064-064
			Segment 65		065-065
			Segment 66		066-066

			Segment 67		067-067
			Segment 68		068-068
			Segment 69		069-069
			Segment 70		070-070
			Segment 71		071-071
			Segment 72		072-072
			Segment 73		073-073
			Segment 74		074-074
			Segment 75		075-075
			Segment 76		076-076
			Segment 77		077-077
			Segment 78		078-078
			Segment 79		079-079
			Segment 80		080-080
			Segment 81		081-081
			Segment 82		082-082
			Segment 83		083-083
			Segment 84		084-084
			Segment 85		085-085
			Segment 86		086-086
			Not used		087-099

				Numerary 0-4		100-104
				Numerary 5-9		105-109
				Smiley small		110-110
				Smiley big		111-111
				Not used		112-219
				Static segment 1		220-220
				Static segment 2		221-221
				Static segment 3		222-222
				Static segment 4		223-223
				Static segment 5		224-224
				Static segment 6		225-225
				Static segment 7		226-226
				Static segment 8		227-227
				Static segment 8		228-228
				Static segment 10		229-229
				Static segment 11		230-230
				Not used		231-255
10	10	10	10	<b>Pattern mode</b> <b>Block 0-31: RGBW LED's of the inactive segment are deactivated.</b> Pattern faded Pattern switch Pattern switch with cross fade clockwise Pattern switch with cross fade anti clockwise Pixel random flash fast Pixel random snap open / ramp close Pixel random flash slow Pixel random ramp open / snap close	} regular interval	000-000 001-001 002-002 003-003 004-004 005-005 006-006 007-007

			Pixel random flash fast	}	random interval	008-008	
			Pixel random snap open / ramp close			009-009	
			Pixel random flash slow			010-010	
			Pixel random ramp open / snap close			011-011	
			Static effects			012-031	
			<b>Block 32-63: RGBW LED's of the inactive segment illuminate in foreground (pattern) color</b>				
			Pattern faded			032-032	
			Pattern switch			033-033	
			Pattern switch with cross fade clockwise			034-034	
			Pattern switch with cross fade anti clockwise			035-035	
			Pixel random flash fast	}	regular interval	036-036	
			Pixel random snap open / ramp close			037-037	
			Pixel random flash slow			038-038	
			Pixel random ramp open / snap close			039-039	
			Pixel random flash fast	}	random interval	040-040	
			Pixel random snap open / ramp close			041-041	
			Pixel random flash slow			042-042	
			Pixel random ramp open / snap close			043-043	
			Static effects			044-063	
			<b>Block 64-95: RGBW LED's of the inactive segment illuminate in background (main) color</b>				
			Pattern faded			064-064	
			Pattern switch			065-065	
			Pattern switch with cross fade clockwise			066-066	
			Pattern switch with cross fade anti clockwise			067-067	
			Pixel random flash fast	}	regular interval	068-068	
			Pixel random snap open / ramp close			069-069	
			Pixel random flash slow			070-070	
			Pixel random ramp open / snap close			071-071	
			Pixel random flash fast	}	random interval	072-072	
			Pixel random snap open / ramp close			073-073	
			Pixel random flash slow			074-074	
			Pixel random ramp open / snap close			075-075	
			Static effects			076-095	
			<b>Block 96-127: RGBW LED's of the inactive segment illuminate in Glow RGBW color. Glow RGBW overlays also the active LEDs.</b>				
			Pattern faded			096-096	
			Pattern switch			097-097	
			Pattern switch with cross fade clockwise			098-098	
			Pattern switch with cross fade anti clockwise			099-099	
			Pixel random flash fast	}	regular interval	100-100	
			Pixel random snap open / ramp close			101-101	
			Pixel random flash slow			102-102	
			Pixel random ramp open / snap close			103-103	
			Pixel random flash fast	}	random interval	104-104	
			Pixel random snap open / ramp close			105-105	
			Pixel random flash slow			106-106	
			Pixel random ramp open / snap close			107-107	
			Static effects			108-127	
			<b>Block 128-159: RGBW LED's of the inactive segment illuminate in Glow RGBW color. Only the inactive LEDs illuminate in Glow RGBW color.</b>				
			Pattern faded			128-128	
			Pattern switch			129-129	
			Pattern switch with cross fade clockwise			130-130	
			Pattern switch with cross fade anti clockwise			131-131	
			Pixel random flash fast	}	regular interval	132-132	
			Pixel random snap open / ramp close			133-133	
			Pixel random flash slow			134-134	
			Pixel random ramp open / snap close			135-135	

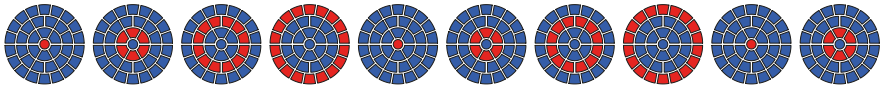
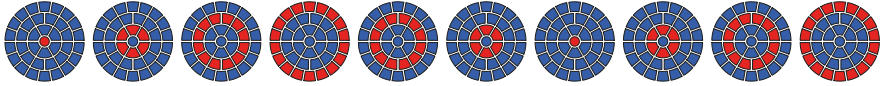
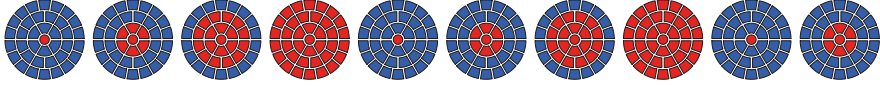
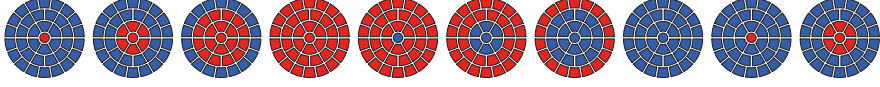
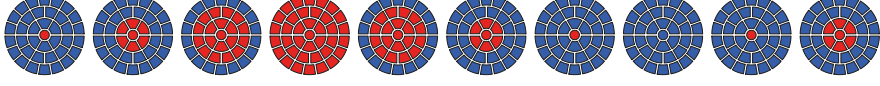
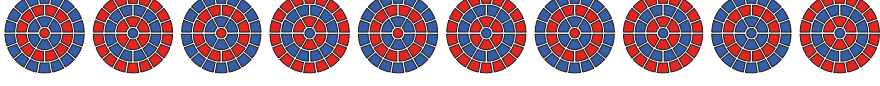
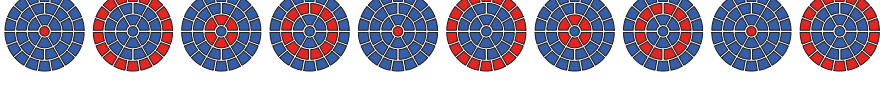
				Pixel random flash fast Pixel random snap open / ramp close Pixel random flash slow Pixel random ramp open / snap close Static effects <b>Block 160-191: same as block 0-31 without glow RGBW. (use together with color spread channel - working with foreground color.</b> Pattern faded Pattern switch Pattern switch with cross fade clockwise Pattern switch with cross fade anti clockwise Pixel random flash fast Pixel random snap open / ramp close Pixel random flash slow Pixel random ramp open / snap close Pixel random flash fast Pixel random snap open / ramp close Pixel random flash slow Pixel random ramp open / snap close Static effects Macro area, combined effects included mappings, pattern mode and patterns Not used	} random interval } regular interval } random interval	136-136 137-137 138-138 139-139 140-159  160-160 161-161 162-162 163-163 164-164 165-165 166-166 167-167 168-168 169-169 170-170 171-171 172-191 192-235  236-255
11	11	11	11	<b>Pattern</b> Pattern off Pattern 01  Pattern 02  Pattern 03  Pattern 04  Pattern 05  Pattern 06  Pattern 07  Not used Random Pattern Not used	000-000 001-001  002-002  003-003  004-004  005-005  006-006  007-007  008-127 128-135 136-255	

12	12	12	12	<b>Pattern speed</b> Clockwise (fast -> slow) Stop Anti clockwise (slow -> fast)	000-126 127-128 129-255
13	13	13	13	<b>Color spread</b> Color spread off Color spread snap increasing indexable clockwise Color spread snap increasing clockwise (fast - slow) Stop Color spread snap decreasing anti clockwise (slow - fast) Color spread fade decreasing indexable anti clockwise Color spread fade decreasing anti clockwise (fast - slow) Stop Color spread fade decreasing anti clockwise (slow - fast)	000-000 001-063 064-094 095-096 097-127 128-191 192-222 223-224 225-255
14	14	14	14	<b>Sparkle</b> Sparkle effect off Sparkle effect intensity (minimum - maximum)	000-000 001-255
15	15	15	15	<b>Sparkle speed</b> Sparkle effect faded (slow - fast) Sparkle effect switched (slow - fast) Repeat of fade and switch block	000-031 032-063 064-255
16	16	16	16	<b>CTC 0 - 100%</b>	000-255
17	17	17	17	<b>Fixed colors</b> Inactive: RGB color mixing active White White / red Red Red / yellow Yellow Yellow / magenta Magenta Magenta / green Green Green / orange Orange Orange / blue Blue Blue / turquoise Turquoise Turquoise / white White 2700 kelvin White 2700 kelvin, tungsten fade out White 3200 kelvin White 3200 kelvin, tungsten fade out White 4200 kelvin White 5600 kelvin White 6500 kelvin White 8000 kelvin Color change effect (fast to slow) Color change effect (stop) Color change effect (slow to fast)	000-001 002-003 004-007 008-011 012-015 016-019 020-023 024-027 028-031 032-035 036-039 040-043 044-047 048-051 052-055 056-059 060-063 064-064 065-065 066-066 067-067 068-068 069-069 070-070 071-191 192-222 223-224 225-255

18	18	18	18	<b>Pan/tilt speed</b> Movement in real time Movement delayed (fast to slow)		000-003 004-255
19	19	19	19	<b>Effect speed</b> Effects in real time Effects delayed (fast to slow)		000-003 004-255
20	20	20	20	<b>Blackout move</b> Not used Shutter working on selected mapping Not used Blackout at PAN/TILT movement Blackout at color change Not used Blackout at color change and PAN/TILT movement dimmer fade time can be adjusted from slow (5sec) to fast		000-000 001-070 071-095 096-127 128-159 160-223 224-255
21	21		21	<b>Red (8 Bit) 0-100%</b>	} Glow RGBW	000-255
	22			<b>Red fine (16 Bit) 0-100%</b>		000-255
22	23		22	<b>Green (8 Bit) 0-100%</b>		000-255
	24			<b>Green fine (16 Bit) 0-100%</b>		000-255
23	25		23	<b>Blue (8 Bit) 0-100%</b>		000-255
	26			<b>Blue fine (16 Bit) 0-100%</b>		000-255
24	27		24	<b>White (8 Bit) 0-100%</b>		000-255
	28			<b>White fine (16 Bit) 0-100%</b>		000-255
25	29	21	25	<b>Red (8 Bit) 0-100%</b>	} Main RGBW	000-255
	30			<b>Red fine (16 Bit) 0-100%</b>		000-255
26	31	22	26	<b>Green (8 Bit) 0-100%</b>		000-255
	32			<b>Green fine (16 Bit) 0-100%</b>		000-255
27	33	23	27	<b>Blue (8 Bit) 0-100%</b>		000-255
	34			<b>Blue fine (16 Bit) 0-100%</b>		000-255
28	35	24	28	<b>White (8 Bit) 0-100%</b>		000-255
	36			<b>White fine (16 Bit) 0-100%</b>		000-255

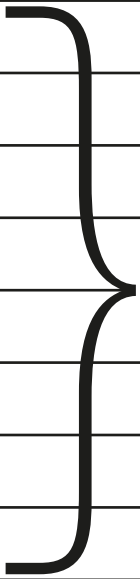
29	37		29	<b>Red (8 Bit) 0-100%</b>	 Pattern RGBW	000-255
	38			<b>Red fine (16 Bit) 0-100%</b>		000-255
30	39		30	<b>Green (8 Bit) 0-100%</b>		000-255
	40			<b>Green fine (16 Bit) 0-100%</b>		000-255
31	41		31	<b>Blue (8 Bit) 0-100%</b>		000-255
	42			<b>Blue fine (16 Bit) 0-100%</b>		000-255
32	43		32	<b>White (8 Bit) 0-100%</b>		000-255
	44			<b>White fine (16 Bit) 0-100%</b>		000-255
			33	<b>Transition/crossfade effect engine - single LED control 0-100%</b>	000-255	
			34	<b>Red (LED group 1) 0-100%</b>	000-255	
			35	<b>Green (LED group 1) 0-100%</b>	000-255	
			36	<b>Blue (LED group 1) 0-100%</b>	000-255	
			37	<b>White (LED group 1) 0-100%</b>	000-255	
			38	<b>Red (LED group 2) 0-100%</b>	000-255	
			39	<b>Green (LED group 2) 0-100%</b>	000-255	
			40	<b>Blue (LED group 2) 0-100%</b>	000-255	
			41	<b>White (LED group 2) 0-100%</b>	000-255	
			42	<b>Red (LED group 3) 0-100%</b>	000-255	
			43	<b>Green (LED group 3) 0-100%</b>	000-255	
			44	<b>Blue (LED group 3) 0-100%</b>	000-255	
			45	<b>White (LED group 3) 0-100%</b>	000-255	
			46	<b>Red (LED group 4) 0-100%</b>	000-255	
			47	<b>Green (LED group 4) 0-100%</b>	000-255	
			48	<b>Blue (LED group 4) 0-100%</b>	000-255	
			49	<b>White (LED group 4) 0-100%</b>	000-255	

		50	<b>Red (LED group 5) 0-100%</b>	000-255
		51	<b>Green (LED group 5) 0-100%</b>	000-255
		52	<b>Blue (LED group 5) 0-100%</b>	000-255
		53	<b>White (LED group 5) 0-100%</b>	000-255
		162	<b>Red (LED group 33) 0-100%</b>	000-255
		163	<b>Green (LED group 33) 0-100%</b>	000-255
		164	<b>Blue (LED group 33) 0-100%</b>	000-255
		165	<b>White (LED group 33) 0-100%</b>	000-255
		166	<b>Red (LED group 34) 0-100%</b>	000-255
		167	<b>Green (LED group 34) 0-100%</b>	000-255
		168	<b>Blue (LED group 34) 0-100%</b>	000-255
		169	<b>White (LED group 34) 0-100%</b>	000-255
		170	<b>Red (LED group 35) 0-100%</b>	000-255
		171	<b>Green (LED group 35) 0-100%</b>	000-255
		172	<b>Blue (LED group 35) 0-100%</b>	000-255
		173	<b>White (LED group 35) 0-100%</b>	000-255
		174	<b>Red (LED group 36) 0-100%</b>	000-255
		175	<b>Green (LED group 36) 0-100%</b>	000-255
		176	<b>Blue (LED group 36) 0-100%</b>	000-255
		177	<b>White (LED group 37) 0-100%</b>	000-255
		178	<b>Red (LED group 37) 0-100%</b>	000-255
		179	<b>Green (LED group 37) 0-100%</b>	000-255
		180	<b>Blue (LED group 37) 0-100%</b>	000-255
		181	<b>White (LED group 34) 0-100%</b>	000-255

## Arrangement of the LED groups 1-37

The Pan/Tilt values are at 127/60. The display of the fixture is looking in the same direction like the LED's

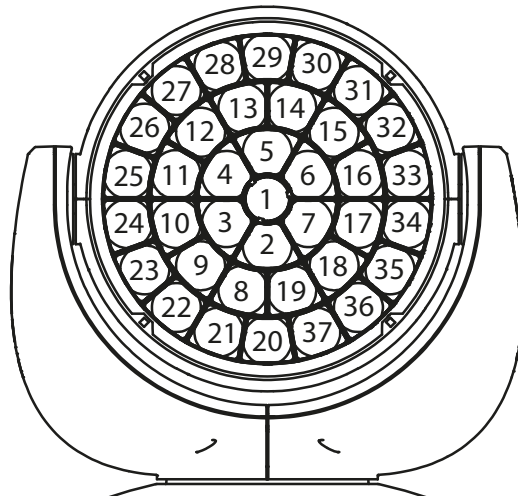

### 5.1 Color mixing

The Sparx10 features a color wheel emulation, main RGBW, pattern RGBW, glow RGBW and CTC channel. The color wheel emulation has priority. Only if the color wheel emulation is set to DMX value 000-001 it is possible to operate the RGBW channels. The glow RGBW is used for glow effects and can overlay the other colors. The CTC channel can be combined with both the RGBW channels and the color wheel emulation. If the effect channels 9-13 are in use, the main RGBW is used as background color and the pattern RGBW is used as foreground color (pattern color). If color wheel emulation is active (DMX value > 001) the main RGBW is still used as background color but the effects ( foreground - pattern) are working with the color wheel emulation. Pattern RGBW has no function in this juncture.

### 5.2 Control channel

The control channel (channel 5) offers additional control over the RGB-channels.

**DMX 000-007:** no white balance active.

**DMX 008-015:** basic adjustment on the RGB channels. So it's possible to have always the same white from different production series (factory adjustment). Marginal reduced intensity of the RGBW strings.

**DMX 016-023:** White balance, reduced intensity in blue, possible reduction in intensity of green and red. If fixtures are set to this DMX value the white of color wheel emulation (color 0) and RGB color mixing is the same.

**DMX 024-031:** White balance same to DMX 016-023, plus the RGBW curves are working in linear mode so it is possible to use the color picker function of various lighting control desks.

These areas are repeated 5 times to adapt the response of the Sparx10 to lighting controls from different manufacturers. The response runs from fast (mode 1) to slow (mode 5).

### 5.3 User notes

#### Control channel 5

Some lighting desks have a delay during DMX refreshing and DMX values get missed during a fade out or using the fader. That means the Sparx10 with his fast reaction time rate this happen as a shutter and shows flickering in the beam. To avoid this you can select 5 different operating modes. Depending on the mode, the reaction time of the Sparx10 gets lower.

**Mapping - channel 9**

The mapping channel split the circular patterns from pattern channel to different LED segments.

**Pattern mode - channel 10**

Is an overall channel for mapping, pattern und pattern speed. The pattern mode controls if a effect is fade, switch, static or a pixel flash. Also a macro area helps fast programming.-

**Pattern / Pattern speed - channel 11/12**

This channel provides 7 increasing, decreasing and random patterns and can controlled by speed and direction with the pattern speed channel. Without mapping channel, the patterns run in circular form. The pattern mode as overall controls the kind of running.

**Color spread - channel 13**

This channel generates an indexable and rotatable color spread on the foreground color of the running effect.

**Sparkle / Sparkle speed - channel 14/15**

This is the name given channel of the Sparx10. This channel offers a unique sparkling effect additional with dimmer and zoom channel. The beam is splitted to the ground colors of the beam depending on the intensity of the channel value. That means full colors get in sparkling forms to fade in and fade out effects. A mixed color is splitted to the ground colors.

**Examples for use of channels 9 to 15**

In the following table you will find some configurations of the channels to create patterns and effects. This table you can use as a template to create your own patterns and effects.

Mapping CH09	Pattern Mode CH10	Pattern CH11	Pattern Speed CH12	Glow R CH21	Glow G CH22	Glow B CH23	Main R CH25	Main G CH26	Main B CH27	Pattern R CH39	Pattern G CH30	Pattern B CH31	Sparkle CH14	Sparkle Speed CH15
000	001	001	026	000	000	000	000	000	255	255	000	000	000	000
080	000	005	013	000	000	000	000	000	255	255	108	000	000	000
079	128	001	004	000	255	000	000	000	255	255	000	000	000	000
086	004	004	004	000	000	000	000	000	066	255	255	171	000	000
027	001	001	026	000	000	000	000	000	255	255	000	000	000	000
033	129	004	005	255	255	171	000	000	255	255	000	000	000	000
086	006	004	008	000	000	000	000	000	080	255	255	171	000	000
110	012	001	000	000	000	000	000	000	255	255	255	171	000	000
111	012	001	008	000	000	000	000	000	255	255	255	171	000	000
000	000	000	000	000	000	000	255	000	255	000	000	000	201	010

**Channel 33 (Transition) only available in Mode 4**

With channel 33 can be switched between the internal effect engine and the real individual LED control. If you send on channel 33 a DMX value of 255, the moving head works 100% in single-LED control. Than the following channels 34-181 used to control the individual LEDs in red, green, blue, white. The figure shows the arrangement of the LED groups if PAN/TILT values are 127/60, the fixture is standing and the display of the fixture is looking in the same direction like the LED's.

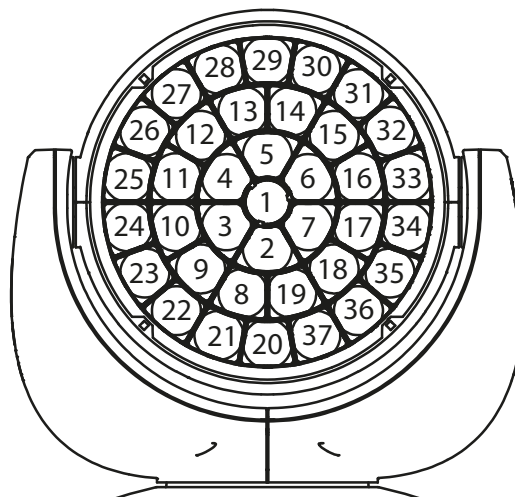

## 6. Service

### 6.1 Service menu

#### **RESET FIXTURE**

This menu offers the command to reset the Sparx10 and can be used as a first remedy if an error occurs.

#### **ERROR LIST**

The ERROR LIST command displays a list of any errors detected. An error can simply be a harmless and isolated incident, but if repeated errors occur, the Sparx10 may require service or repair.

#### **FUNCTION TEST**

This menu provides a general test of all effects. It allows testing the Sparx10 without controller. The re-positioning of pan/tilt is disabled.

#### **LED TEST**

The Sparx10 check LED by LED on functionality. If a LED non working a error code will be displayed with the position of the LED and the kind of failure. Failure could be a short or open of the LED, or the driver of the LED.

#### **DMX TEST**

This menu view the DMX values received on each channel. If the Sparx10 does not behave as expected, reading the DMX values can help to troubleshoot.

#### **INIT PAN TILT**

The INIT PAN TILT feature reinitializes pan and tilt relative to their end stops. Use this feature if pan and tilt appear to have lost the calibration, that means if the pan or tilt beat the reset point or loose the find back position or if you have changed the pan/tilt pcb. This process will take approx. 10 minutes and finishes with a reset.

#### **DISPLAY CONTRAST**

During a heating treatment the contrast of the LCD display can vary. The setting of the contrast can be changed in this menu.

#### **FINE ADJUST**

##### White balance:

The white balance is done by the manufacturer and must be adjusted only in individual special cases. The intensity of the LEDs might vary due to the process of manufacturing. In generally LED manufacturer select their products to so-called binning. All Sparx10 are being adjusted to a reference product before they will be delivered, to make sure that there are no variations.

In order to perform a white balance the brightness of the light sources of red, green, blue and white can be adjusted individually.

Therefore connect a DMX console to the Sparx10 and turn it on. Adjust the Sparx10 to make in a distance of about 8 meters from the wall a white dot with a diameter of about 2 meters. The RGBW channels must be set to DMX 255 each! Now select at Sparx10 the menu item SERVICE -> FINE ADJUST. Enter the FINE ADJUST menu by pressing „ENTER“ (keep pressed) and press „ESC“ additionally. In the following menu item SKAL RED, SKAL GREEN, SKAL BLUE and SKAL WHITE the intensity of red, green, blue and white can be adjusted. Change the value by means of keys „UP“ and „DOWN“. The light beam will be altered according to the received input. Pay attention, that one color value stays at 100%. Otherwise the brightness of the unit will be reduced. The intensity of the fixture can be adjusted from 0% -100% with SKAL ALL. There is no pan & tilt readjustment during this process.

Setting the fixture back to factory defaults will not effect the white balance (chapter 4.2). The fine adjust always influences the function color wheel emulation and RGBW colour mixing only if selected at control channel 5. So for instance if one of the RGBW channels has been reduced significantly the colors of the color wheel emulation will appear different compared to standard factory settings.

### Zoom & focus:

The zoom effect in all Sparx10 is calibrated at the factory. But if necessary it is possible to fine-tune the zoom using the ZOOM OFS command.

### **RECEIVESOFT**

Use the RECEIVE SOFT command to prepare the Sparx10 for a software upload. See 6.3 software update and the uploader device documentation.

## **6.2 Cleaning the fixture**



### WARNING:

Disconnect fixture from mains, and allow unit to cool down for at least 10 minutes! With direct view on the beam source use a welding goggle of reduction 4-5!



### ATTENTION:

Débranchez l'appareil du secteur et le laissé refroidir au moins 10 minutes! Lors d'un regard direct dans la source lumineuse il est fortement recommandé de porter une lunettes de soudeur équipée de verres à vision atténué degré 4-5!!

To ensure a long and satisfying performance of the fixture, check function of the fans in the head and in the base from time to time. Most important: make sure that there is no dust or fluff covering the louvres. To clean the fixture open the head cover and the baseplate. Use a brush and a vacuum cleaner to remove dust and fluff. Don't damage or bend any parts. Incompetent performance of the maintenance will invalidate the warranty claims. Consult qualified service technician!

## **6.3 Software update**

To update the fixture via PC/Notebook, a upgrade dongle (USB/DMX converter) with software is required. The upgrade dongle has to be connected to the fixture with a 5 pin XLR connector. The software for the products is available from the JB-Lighting homepage at [www.jb-lighting.de](http://www.jb-lighting.de).

## **6.4 Verifying electronic devices**

In accordance with the applicable German safety regulations (Accident Prevention and Insurance, DGUV regulation 3 / regulation 4), electrical installation and equipment have to undergo inspection at regular intervals. For this purpose, the fixing screw of the 5-pin DMX socket may serve as measuring point for the insulation and fault current measurement. This screw is connected to all sheet metal parts by means of a contact disc.



PE - measurement point

## 7. Specifications

### Dimension and weight

Length . . . . .	403,8 mm
Width . . . . .	264,8 mm
Height . . . . .	480,0 mm
Weight net / gross . . . . .	12,25 / 14,70 kg

### Electronic

Mains . . . . .	100-240 V AC, 50-60Hz
Maximum power consumption . . . . .	600 VA
Power consumption (standby) . . . . .	46,5 VA

### Temperature

Maximum environmental temperature . . . . .	40 °C
Minimum environmental temperature . . . . .	5 °C

### Optic, photo metrical data

Light source . . . . .	37 RGBW LEDs (15 watt class)
Illumination . . . . .	12200 lumen (zoom max.) 9300 lumen (zoom min.)

### Effects

Pan . . . . .	433,6°
Tilt . . . . .	333,3°
Zoom . . . . .	4°- 40°
Color temperature . . . . .	CTO, variable 12500K-2500K

### Construction

Color . . . . .	black
Housing . . . . .	PC ABS
Protection class . . . . .	IP 20

### Installation

Place of installation . . . . .	indoor
Mounting . . . . .	2x omega brackets
Mounting position . . . . .	any
Minimum distance to flammable items . . . . .	1,0 m

### Connections

Power-In . . . . .	Neutrik PowerCon NAC3MPA (blue)
Power-Thru . . . . .	Neutrik PowerCon NAC3MPB (grey)
DMX in / out USITT DMX512 . . . . .	5-pin, 3-pin in/out XLR

## 8. Declaration of conformity



### Declaration of Conformity

in terms of directive 2014/35/EU - low voltage directive  
(Directive 2014/35/EU of the council from 26. February 2014 on the harmonisation of the laws of Member States relating to electrical equipment designed for use within certain voltage limits)

in terms of directive 2014/30/EU - electromagnetic compatibility  
(Directive 2014/30/EU of the council from 26. February 2014 on the approximation of the laws of the Member States relating to electromagnetic compatibility)

The Manufacturer

**JB-lighting Lichtenlagentechnik GmbH**  
**Sallersteigweg 15**  
**89134 Blaustein-Wipplingen**

declare that the product

**Sparx10**

is in agreement with the safety requirements of this directives. Following standards are contained in the evaluation of the declaration of conformity:

#### **Emission - requirements according to: EN 55022:2010**

Conducted emissions  
EN 55022:2010  
Radiated emissions  
EN 55022:2010  
Harmonic current emissions  
EN 61000-3-2:2015

Flicker  
EN 61000-3-3

#### **Information technology equipment - Radio disturbance characteristics - Limits and methods of measurements - Class A**

Information technology equipment - Radio disturbance characteristics - Limits and methods of measurements - Class A  
Information technology equipment - Radio disturbance characteristics - Limits and methods of measurements - Class A  
Electromagnetic compatibility (EMC)  
part 3-2: Limits - Limits for harmonic current emissions (equipment input current < 16A per phase)  
Electromagnetic compatibility (EMC)  
part 3-3: Limits - Limitation of voltage changes, voltage fluctuation and flicker in public low-voltage supply systems, for equipment with rated current < 16 A per phase and not subjected to conditional connection

#### **Immunity - Requirements according to DIN EN 61000-6-2:2005**

EN 61000-4-2:2009  
EN 61000-4-3: 2006 + A1:2008 + A2:2010  
EN 61000-4-4:2012  
EN 61000-4-5:2006  
EN 61000-4-6:2014  
EN 61000-4-8:2010  
EN 61000-4-11:2004

#### **Electromagnetic compatibility (EMC) - Part 6-2: Generic standards - Immunity for industrial environments**

Part 4-2: Testing and measurements techniques  
Electrostatic discharge immunity test  
Part 4-3: Testing and measurements techniques  
Radiated, radio-frequency, electromagnetic field immunity test  
Part 4-4: Testing and measurements techniques  
Electrical fast transient/burst immunity test  
Part 4-5: Testing and measurements techniques  
Surge immunity test  
Part 4-6: Testing and measurements techniques  
Immunity to conducted disturbances, induced by radio-frequency fields  
Part 4-8: Testing and measurements techniques  
Power frequency magnetic field immunity test  
Part 4-11: Testing and measurements techniques  
Voltage dips, short interruptions and voltage variations immunity tests

Blaustein, 01.11.2014

Jürgen Brauhgardt  
Managing Director

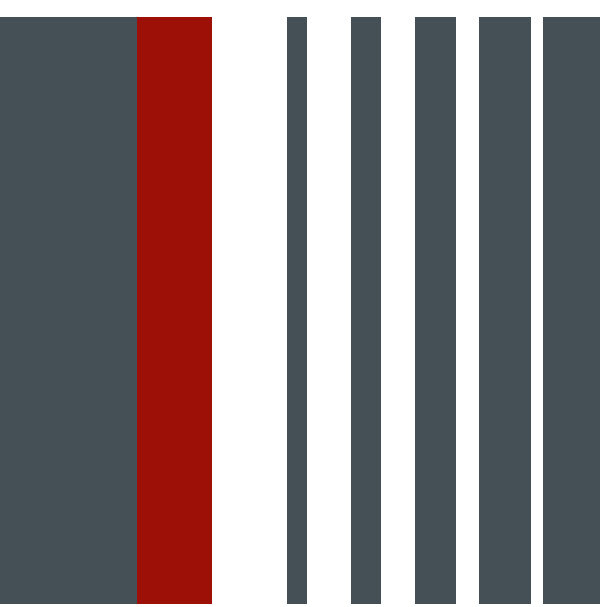

JB-Lighting Lichtanlagentechnik GmbH  
Sallersteig 15  
89134 Blaustein  
Tel. +49 7304 9617-0  
Fax. +49 7304 9617-99  
info@jb-lighting.de  
www.jb-lighting.de

**JB LIGHTING**